



Outdoor Lighting Techniques

There are many outdoor lighting techniques that can be created using the lighting products available from **Lucie ed Ombre**. Below you will find a description of the outdoor lighting techniques.

Accent & Spotlighting

A quick way to add drama to a landscaped garden. Position intense and focussed lights near the base of statuary or trees or near a surfaced wall or trellis. This technique is very compelling but should be used sparingly.

Cross Outdoor Garden Lighting

If your aim is to show off a beautiful statue or an old gnarled tree, you'll love the softly flattering light that is produced by cross garden lighting. To do this, position a spotlight on either side of the object you wish to illuminate, whether natural or man - made. The multiple beams of light produce softer shadows and reveal more detail.

Downlighting

Downlighting is recommended as an effective and affordable method for security outdoor lighting. To illuminate large areas position bright spotlights near the roof of your home. To light a pathway, mount smaller luminaires near the ground.

Path and Outdoor Lighting

There is perhaps nothing more beckoning than a well lit garden path. Place low level on either side of a path or walkway. As an added benefit, path garden lighting provides a safe walkway and adds to your home's security.

Shadowing

If you have a tree or statue with a striking profile in front of a wall or other surface, shadowing may be a very elegant way to add some drama to your exterior. Place recessed luminaires in front of the object to create shadows on the surface beyond.

Silhouetting

The opposite of shadowing, this garden and outdoor lighting technique is equally as simple. Just position a recessed luminaire behind and below the object to create a spectacular silhouette.

Spread Lighting

If you've invested in landscaping your garden with flowerbeds and low shrubs, you'll want to enhance its nighttime appeal with spread lighting. To do this, position luminaires to illuminate low lying landscaping and ground cover.

Moon Lighting

If you have a medium to large size tree try placing one or two low voltage lights, pond lights with glare guards and frosted lenses works well, onto the second or third tier of

ACT

branches and angle the light through. This will create an artificial moonlight effect and be very subtly at the same time as casting light interestingly over the area below.

Uplighting

If a canopy of branches covers your garden, try this technique, place recessed garden and outdoor lighting luminaires in the ground and angle the lamp upwards. The illuminated branches or architecture will provide an interesting point of visual interest and reflect a soft light onto your garden and patio.

The images below show many of the outdoor lighting techniques that can be created by using lighting within your garden

Up-Garden Lighting



Spike Spot

50 Watt 10 Degree

Silhouetting



Lawn Garden Lighting

50 Watt 60 Degree

Shadowing

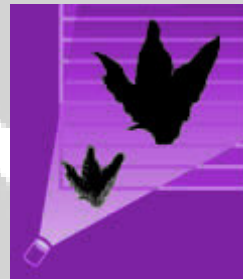

Spike Adjustable

20 Watt 38 Degree

Down Garden Lighting

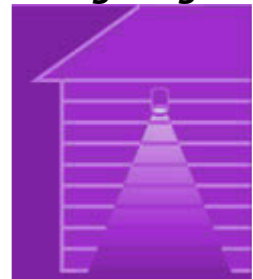

Down Light Retro

20 Watt 60 Degree

Step Garden Lighting



Step Light Eyelid

20 Watt 38 Degree

Path Garden Lighting



Path Light

20 Watt 10 Degree

Fountain Garden Lighting



Pond Light

50 Watt 38 Degree

Swimming Pool



Pool Light

50 Watt 60 Degree



Lamp Wattages & Beam Angle Choices

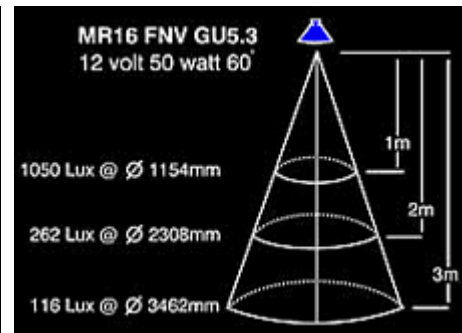
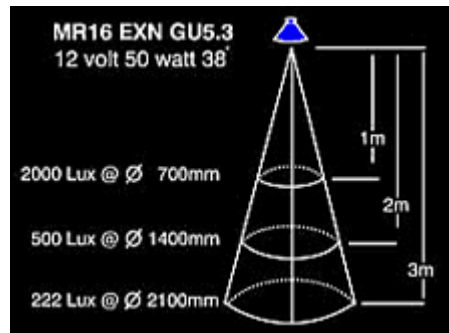
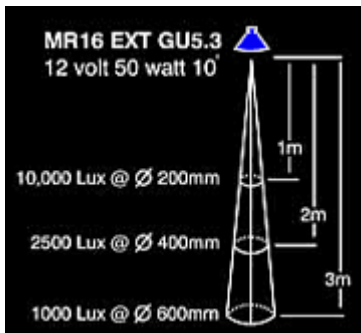
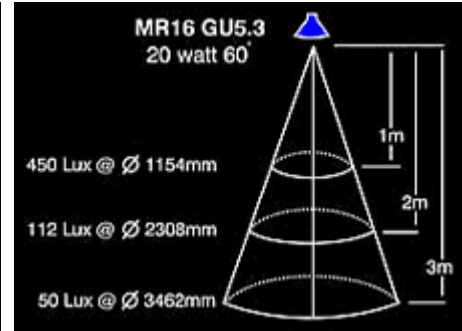
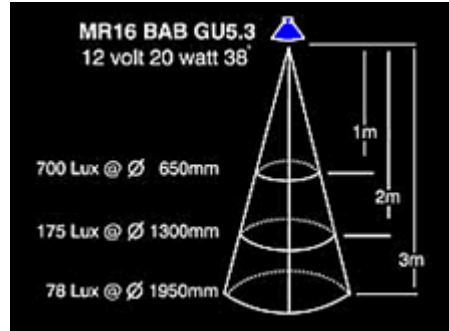
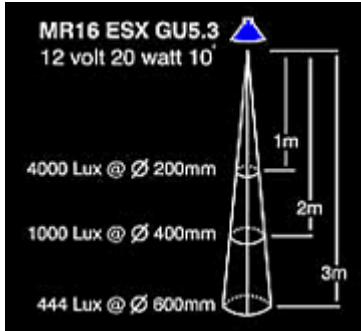

If you have any other questions regarding any of the above outdoor lighting techniques, our products or services then please do not hesitate to contact us.

